

Catalog.

DIRENC METAL®



Precision in Every Detail

Innovative fastening and plumbing solutions for industrial excellence.

Volume 01.

ABOUT US

DIRENC GROUP COMPANY innovates and produces superior quality **fasteners, plumbing kits and accessories** mainly for kitchen industry with its global awareness and long-term family values, **as a partner of the world's leading players.**

DIRENC continues its services with **2 facilities with autonomous production lines** and **1 R&D center with modern laboratories**, leveraging high technology and professional production techniques.

To support the new research and development initiatives within **INARTEN R&D**; communication is maintained with students and professors from various departments at universities **across Turkey and global**, aiming to assist in upcoming projects. Scholarships are provided to students sourced from these universities, offering them the opportunity to intern within our company. In this manner, contribution is made to **the development of personnel capable of adding value to our projects**. Furthermore, efforts are made to set a good example for **collaboration between the public and private sectors.**

DIRENC invests annually in **technology, machinery, and personnel** at a rate equivalent to **13% of its total revenue generated over the years**. As a result of these efforts, **more than 95% of our production is exported to global industry leaders.**

Driven by our **long-term family values and global awareness**, we stand as trusted partners to most of the world's leading players in various industries. Our diverse product range is tailored to meet the stringent requirements of our clients, reflecting our **dedication to excellence in every aspect of our operations.**



Shaping the Future with Timeless Quality

*The Direnc
Advantage*

Mission

is to diligently address our customers' needs through a comprehensive service portfolio. We provide technical support and foster ongoing collaboration in product development, innovation, and quality enhancement. Our commitment lies in striving for excellence while aiding our customers in expanding their businesses within their markets.

Vision

is to set the benchmark for excellence in every product and service we provide. We aspire to be the ultimate partner for our customers and consumers, continuously enhancing our R&D capabilities to drive innovation and ensure unparalleled quality in everything we do.

Milestones

The Past 42 Years

DIRENC GROUP has been a trailblazer in innovation and excellence, shaping a legacy that spans over four decades. It all started in 1982 with the inception of **Mekasan**, focusing on the production of topnotch gaskets and insulation materials.

In 2007, the emergence of **Direnc Metal** marked a pivotal moment for the group. Specializing in crafting clips and fasteners customized for kitchen sinks.



Direnc Metal swiftly became synonymous with precision and functionality, solidifying its position as a leader in the industry. The year 2016 witnessed another milestone with the introduction of **Direnc Plastik**, broadening the group's capabilities to include the production of waste kits and traps tailored for modern kitchens, effectively meeting the evolving market demands while maintaining a commitment to groundbreaking innovation.

As the group continued its ascent, 2018 saw a strategic expansion, with production sites expanding to an impressive 10,000 square meters. Introduction of new production lines further enhanced capabilities, ensuring **Direnc Group's stronghold as an industry leader.**

In 2018, **INARTEN R&D** was established at Yildiz Technical University Technopark to meet the design and innovation needs in the industry. During the establishment phase, Yildiz Technical University Technopark received over 2,000 applications from new start-ups. **INARTEN R&D distinguished itself by ranking in the top 3 with its designs and projects, earning permission to establish a company within the Technopark and invitation letter from Silicon Valley.**

From 2018 to 2023, the group reached a pinnacle with the attainment of over 10 patented products and designs, a testament to its unwavering commitment to excellence and innovation in the industry with the help of a strong team in **Inarten R&D.**

With a legacy built over the past 42 years, DIRENC GROUP has **continuously stood at the forefront of innovation and excellence.** From the establishment of Mekasan in 1982 to the emergence of Direnc Metal, Direnc Plastik and Inarten R&D, the group has **consistently demonstrated its dedication to delivering high-quality products tailored to meet the ever-changing needs of the market.**

- 1982 Birth of MEKASAN with the aim to produce gaskets and insulation materials.
- 2007 Creation of Direnc Metal brand which produces clips and fasteners for kitchen sinks. 
- 2016 Creation of Direnc Plastik brand which produces waste kits and traps for kitchen sinks 
- 2017 First international patent application.

- 2018 Expansion of production sites total about 10,000 square meters with new production lines.
- 2019 Creation of Inarten R&D center in modern university facilities and Silicon Valley Office. 
- 2021 +10 patented products and designs.
- 2023 Gathering under DIRENC GROUP COMPANY by combining joint interests of Direnc Metal, Direnc Plastik and Inarten R&D.

Timeless Quality

Shaping The Future



- 29 metal press and forming lines
- Over 1.000.000.000 metal forming parts production capacity
- Presses from 5 tons to 600 tons
- +150 different designs for kitchen & bath sink clips
- Special parts for automotive and industrial needs
- Automated assembly lines
- 65 employees



- +70 molds for metal parts of waste kits
- +400 different plastic molds for sink waste kits and traps
- 24 plastic injection machinery lines from 60 tons to 400 tons
- Automated packing lines
- 55 employees



- +10 patented products and designs
- International tool designs and production
- CAD & simulation technologies
- Located at one of the best technical university in Istanbul
- Modern laboratory and equipments
- Top-class professional academic supporters

Our

Certificates



ISO 9001:2015

Quality Management System



ISO 14001:2015

Environmental Management System



ISO 45001:2018

Safety Management System



ISO 50001:2018

Energy Management System



Direnc has its brand value from

Company Culture

Quality and Competence

Optimization in World Resources

R&D And Innovation

With over 40 years of experience, DIRENC confidently offers tailored solutions to customers' needs. Our skilled engineers assess initial component designs and can create handmade prototype samples for customer evaluation when necessary.

Utilizing robust 3D CAD design software, prototyping tools, and proficient staff, we develop innovative products that meet customers' functional requirements.

DIRENC's R&D division prioritizes scientific studies and quality principles, aiming to:

- **Minimize quality issues**
- **Provide prompt feedback on problems**
- **Achieve world-class production standards**
- **Enhance existing products**
- **Develop innovative solutions to meet customer needs**

DIRENC is committed to sustainable growth and endeavors to influence future technologies. The role of INARTEN R&D is to prepare DIRENC for the future.

Throughout our R&D endeavors, we prioritize flexibility, solution-oriented approaches, participation, sustainability, ethical values, fostering teamwork, and valuing human capital.



+10 patented products and registered designs



Tool Manufacture & Molding

Innovation
Molded,
Excellence
Defined:
Tools that
Shape
Tomorrow.



Our tool manufacture & molding division stands as the epitome of quality and innovation, shaping tomorrow with excellence. With in-house capabilities for both molding and maintenance processes, we ensure precision at every stage. Our Research and Development team designs molds tailored to perfection, while also providing routine and specialized maintenance for equipment.

Steel Processing



+230 molds for metal parts



29 metal press and forming lines



Over 1.000.000.000 Metal forming parts production capacity



Presses from 5 tons to 600 tons



“Innovative shapes for steel”

Our in-house production capabilities include molding and punching presses, facilitating the manufacturing of all critical components for the final product. We handle processes such as blanking, drawing, coining, and stamping of metal components. DIRENC operates an internal workshop for both routine and exceptional maintenance of all equipment, including molds designed by our R&D department.

Mastery in Plastic Molding



+480 molds for plastic parts



24 plastic injection machinery lines



Machineries from 60 tons to 400 tons

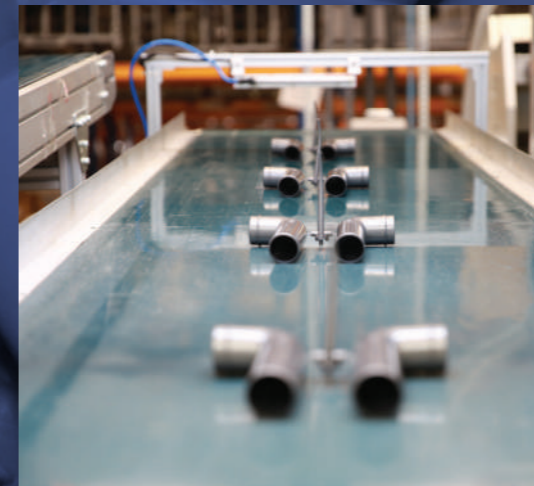

“Innovative direction to your water”

DIRENC possesses extensive expertise and a diverse array of technologically advanced presses for plastic molding.

Utilizing modern techniques and specialized personnel, we consistently produce durable, highquality plastic products. Our production process is automated and monitored by our quality control department to ensure precision and efficiency.

We exclusively source top-quality plastics from European countries to guarantee the excellence of our materials.

Assembly & Packaging

Nine automatic and semi-automatic assembly and packaging lines are equipped with high-precision scales to ensure the quality of products.

All components needed for production are stored in our warehouses and pre-assembled according to specifications detailed in the customer's order. Labels and installation instructions can be created for customers according to needs.

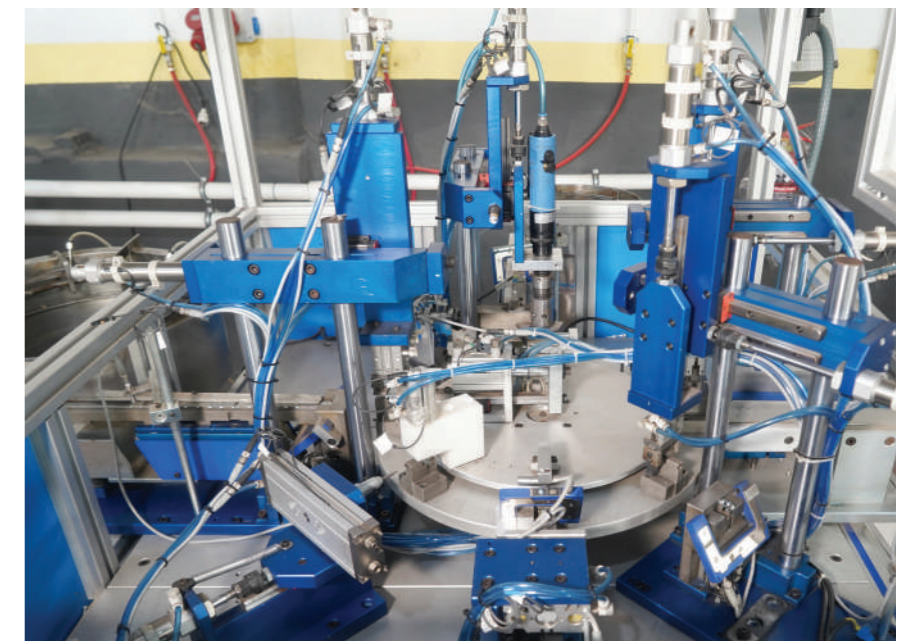

Foam & Isolation Production

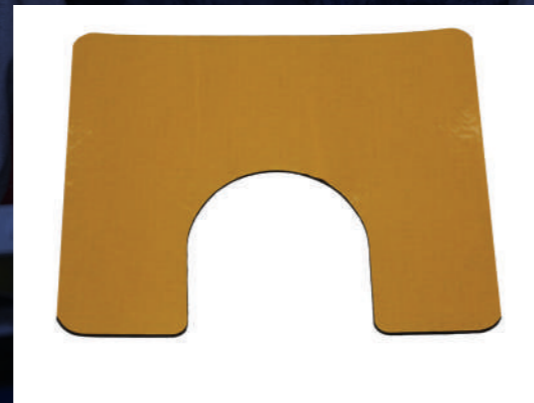

All isolation products within the structure of Direnc Metal are produced for our customers using high-end foam and tape processing machines. Many of the technical materials required by our customers, such as sponge, bitumen, and tape, are produced and processed, providing a wide range of products, services, and solutions.

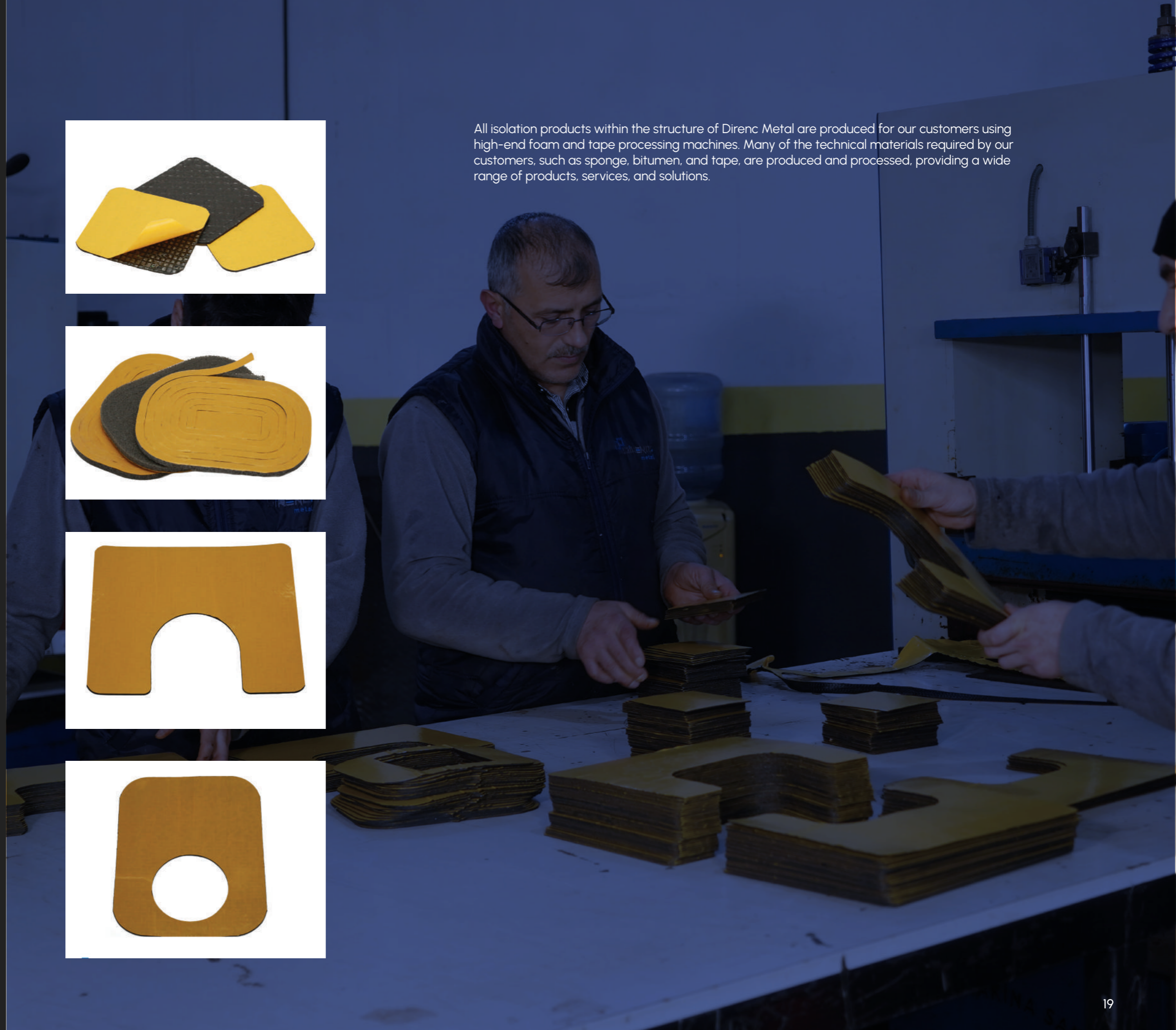

Stainless Steel Sink Clips



23

Composite Granit Sink Clips



31

Undermount Sink Clips

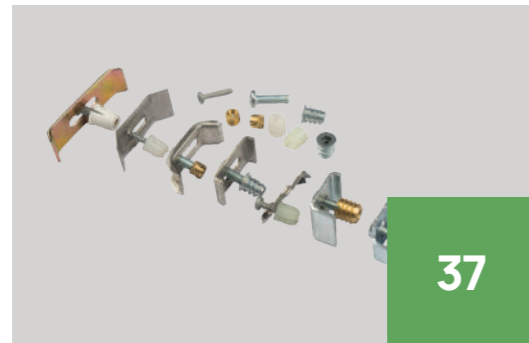

37

Spare Parts



40

Foam & Isolation Products

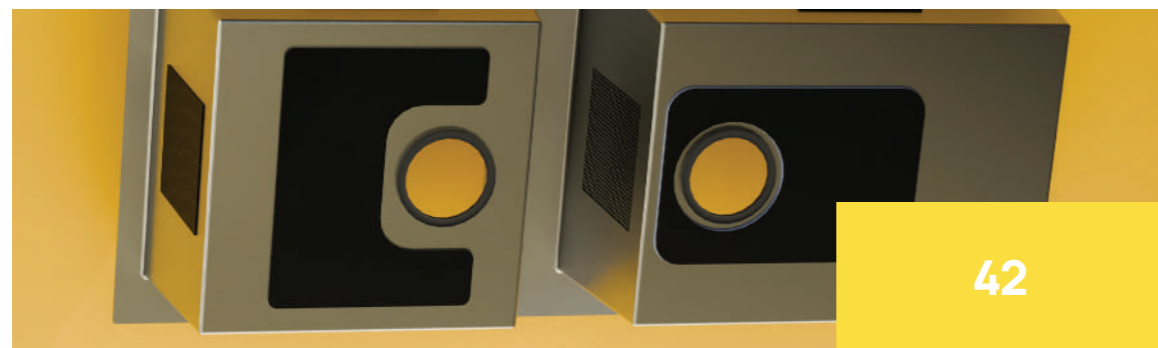

42

STAINLESS STEEL SINK CLIPS



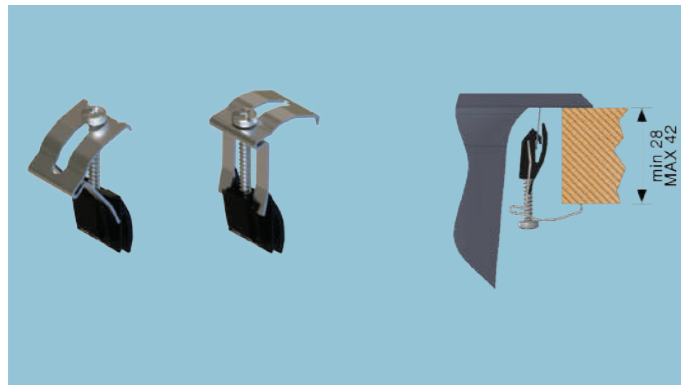

MM-00121

Sink Type: Topmount
Worktop Range: 28-42mm
Raw Material: Spring Steel (C45-C67)
 PA 6.6

Packing Options:
 Unpackaged
 Plastic Bag
 Cardboard box

Unpackaged Code	Master Carton Dims (cm)	PCS/ Box	PCS/ Pallet
MM-00122	55x24x25	2100	75.600

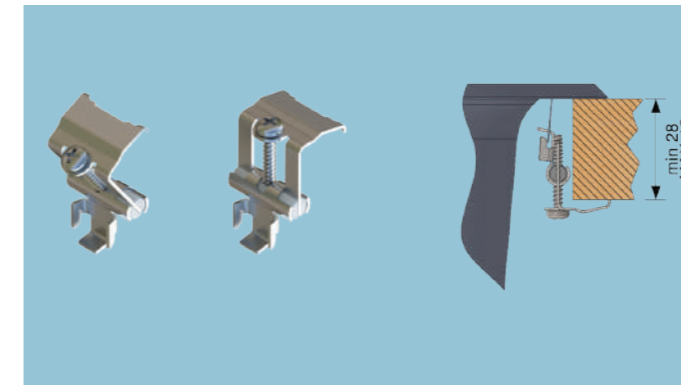

MM-00362

Sink Type: Topmount
Worktop Range: 28-42mm
Raw Material: Spring Steel (C45-C67)
 PA 6.6

Packing Options:
 Unpackaged
 Plastic Bag
 Cardboard box

Unpackaged Code	Master Carton Dims (cm)	PCS/ Box	PCS/ Pallet
MM-00363	55x24x25	2200	79.200

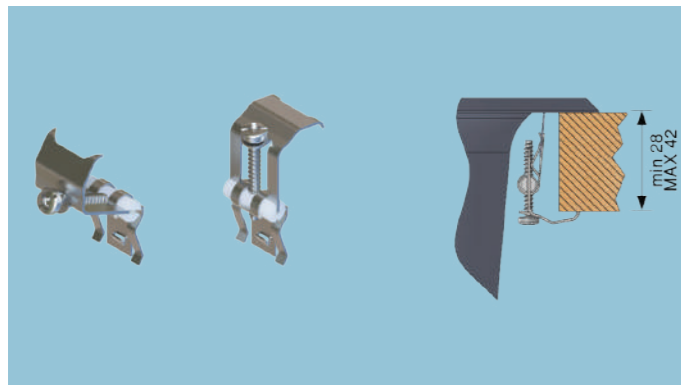

MM-00103

Sink Type: Topmount
Worktop Range: 28-42mm
Raw Material: Spring Steel (C45-C67)
 PA 6.6

Packing Options:
 Unpackaged
 Plastic Bag
 Cardboard box

Unpackaged Code	Master Carton Dims (cm)	PCS/ Box	PCS/ Pallet
MM-00104	55x24x25	2300	82.800

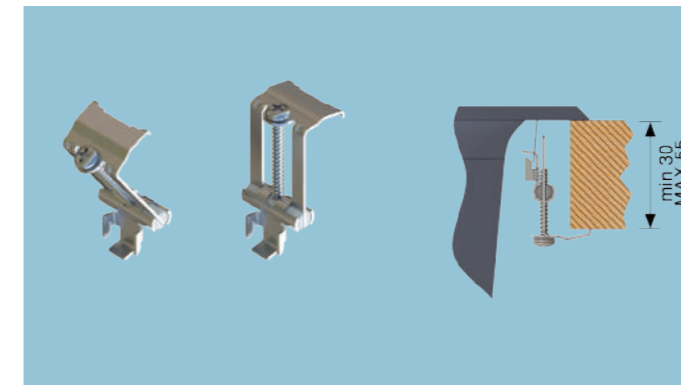

MM-00117

Sink Type: Topmount
Worktop Range: 30-55mm
Raw Material: Spring Steel (C45-C67)
 PA 6.6

Packing Options:
 Unpackaged
 Plastic Bag
 Cardboard box

Unpackaged Code	Master Carton Dims (cm)	PCS/ Box	PCS/ Pallet
MM-00118	55x24x25	2100	75.600

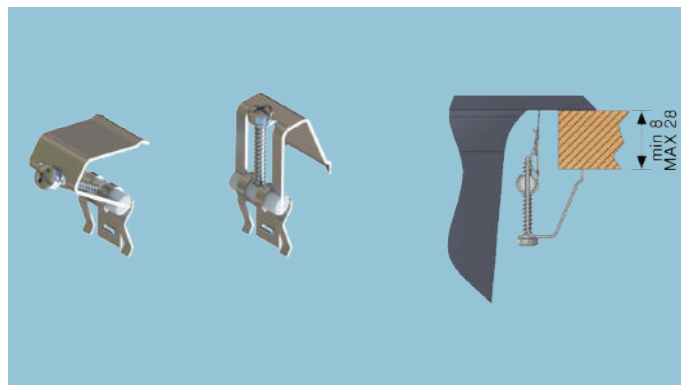

MM-00113

Sink Type: Topmount
Worktop Range: 8-28mm
Raw Material: Spring Steel (C45-C67)
 PA 6.6

Packing Options:
 Unpackaged
 Plastic Bag
 Cardboard box

Unpackaged Code	Master Carton Dims (cm)	PCS/ Box	PCS/ Pallet
MM-00114	55x24x25	2200	79.200



MM-00134

Sink Type: Topmount
Worktop Range: 28-42mm
Raw Material: Spring Steel (C45-C67)
 PA 6.6

Packing Options:
 Unpackaged
 Plastic Bag
 Cardboard box

Unpackaged Code	Master Carton Dims (cm)	PCS/ Box	PCS/ Pallet
MM-00135	55x24x25	2100	75.600

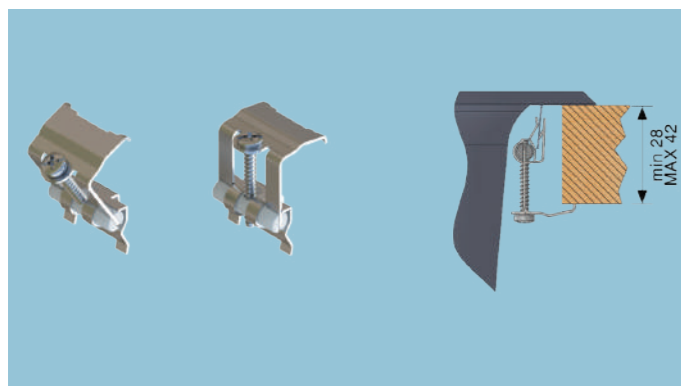

MM-00360

Sink Type: Topmount
Worktop Range: 28-42mm
Raw Material: Spring Steel (C45-C67)
 PA 6.6

Packing Options:
 Unpackaged
 Plastic Bag
 Cardboard box

Unpackaged Code	Master Carton Dims (cm)	PCS/ Box	PCS/ Pallet
MM-00361	55x24x25	2300	82.800



MM-00344

Sink Type: Topmount
Worktop Range: 8-28mm
Raw Material: Spring Steel (C45-C67)
 PA 6.6

Packing Options:
 Unpackaged
 Plastic Bag
 Cardboard box

Unpackaged Code	Master Carton Dims (cm)	PCS/ Box	PCS/ Pallet
MM-00345	55x24x25	2000	72.000



MM-00147

Sink Type: Topmount
Worktop Range: 28-42mm
Raw Material: Spring Steel (C45-C67)
 PA 6.6

Packing Options:
 Unpackaged
 Plastic Bag
 Cardboard box

Unpackaged Code	Master Carton Dims (cm)	PCS/ Box	PCS/ Pallet
MM-00148	55x24x25	2000	72.000

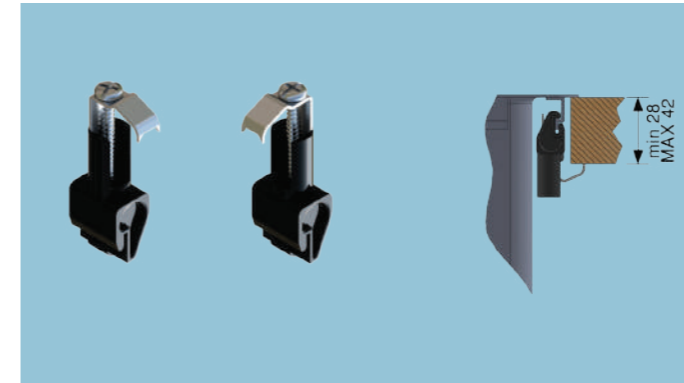

MM-00140

Sink Type: Topmount
Worktop Range: 28-42mm
Raw Material: Spring Steel (C45-C67)
 PA 6.6

Packing Options:
 Unpackaged
 Plastic Bag
 Cardboard box

Unpackaged Code	Master Carton Dims (cm)	PCS/ Box	PCS/ Pallet
MM-00141	55x24x25	2000	72.000

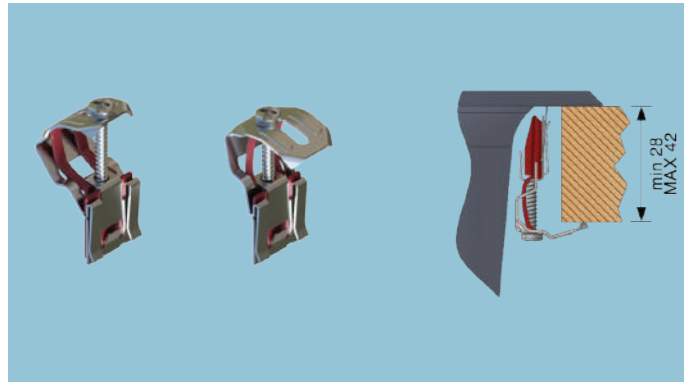

MM-00150

Sink Type: Topmount
Worktop Range: 28-42mm
Raw Material: Spring Steel (C45-C67)
 PA 6.6

Packing Options:
 Unpackaged
 Plastic Bag
 Cardboard box

Unpackaged Code	Master Carton Dims (cm)	PCS/ Box	PCS/ Pallet
MM-00151	55x24x25	2300	82.800



MM-00142

Sink Type: Topmount
Worktop Range: 16-30mm
Raw Material: Spring Steel (C45-C67)
 PA 6.6

Packing Options:
 Unpackaged
 Plastic Bag
 Cardboard box

Unpackaged Code	Master Carton Dims (cm)	PCS/ Box	PCS/ Pallet
MM-00143	55x24x25	2000	72.000



MM-00100

Sink Type: Topmount
Worktop Range: 28-42mm
Raw Material: Spring Steel (C45-C67)
 PA 6.6

Packing Options:
 Unpackaged
 Plastic Bag
 Cardboard box

Unpackaged Code	Master Carton Dims (cm)	PCS/ Box	PCS/ Pallet
MM-00101	55x24x25	2500	90.000



MM-00144

Sink Type: Topmount
Worktop Range: 4-16mm
Raw Material: Spring Steel (C45-C67)
 PA 6.6

Packing Options:
 Unpackaged
 Plastic Bag
 Cardboard box

Unpackaged Code	Master Carton Dims (cm)	PCS/ Box	PCS/ Pallet
MM-00145	55x24x25	2000	72.000

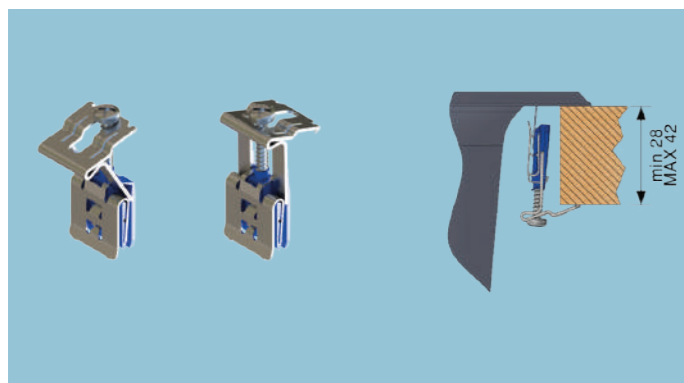

MM-00152

Sink Type: Topmount
Worktop Range: 28-42mm
Raw Material: Spring Steel (C45-C67)
 PA 6.6

Packing Options:
 Unpackaged
 Plastic Bag
 Cardboard box

Unpackaged Code	Master Carton Dims (cm)	PCS/ Box	PCS/ Pallet
MM-00153	55x24x25	2100	75.600



MM-00195

Sink Type: Topmount
Worktop Range: 8-28mm
Raw Material: Spring Steel (C45-C67)
 PA 6.6

Packing Options:
 Unpackaged
 Plastic Bag
 Cardboard box

Unpackaged Code	Master Carton Dims (cm)	PCS/ Box	PCS/ Pallet
MM-00196	55x24x25	2000	72.000

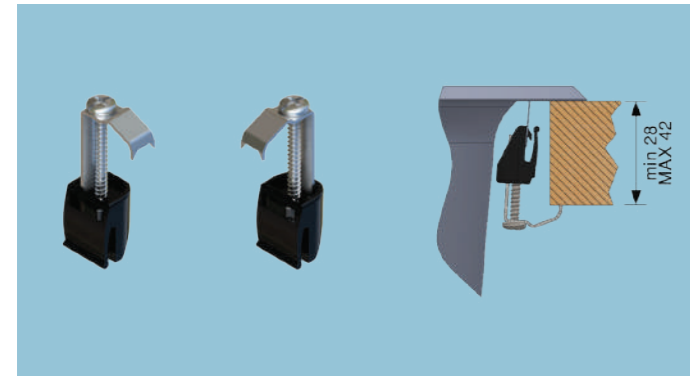

MM-00354

Sink Type: Topmount
Worktop Range: 28-42mm
Raw Material: Spring Steel (C45-C67)
 PA 6.6

Packing Options:
 Unpackaged
 Plastic Bag
 Cardboard box

Unpackaged Code	Master Carton Dims (cm)	PCS/ Box	PCS/ Pallet
MM-00355	55x24x25	2000	72.000

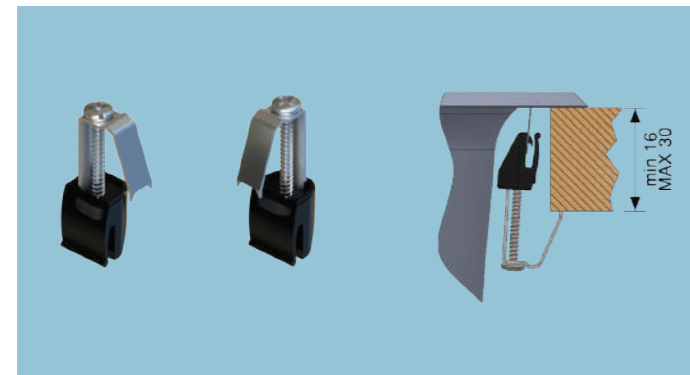

MM-00356

Sink Type: Topmount
Worktop Range: 16-30mm
Raw Material: Spring Steel (C45-C67)
 PA 6.6

Packing Options:
 Unpackaged
 Plastic Bag
 Cardboard box

Unpackaged Code	Master Carton Dims (cm)	PCS/ Box	PCS/ Pallet
MM-00357	55x24x25	2000	72.000



MM-00358

Sink Type: Topmount
Worktop Range: 4-16mm
Raw Material: Spring Steel (C45-C67)
 PA 6.6

Packing Options:
 Unpackaged
 Plastic Bag
 Cardboard box

Unpackaged Code	Master Carton Dims (cm)	PCS/ Box	PCS/ Pallet
MM-00359	55x24x25	2000	72.000

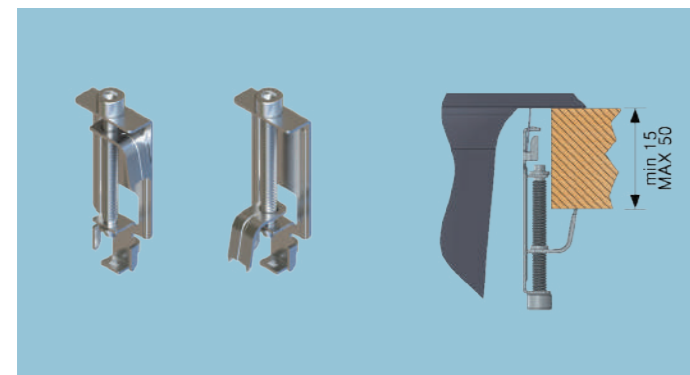

MM-00348

Sink Type: Topmount
Worktop Range: 15-50mm
Raw Material: Spring Steel (C45-C67)
 PA 6.6

Packing Options:
 Unpackaged
 Plastic Bag
 Cardboard box

Unpackaged Code	Master Carton Dims (cm)	PCS/ Box	PCS/ Pallet
MM-00349	55x24x25	1200	43.200

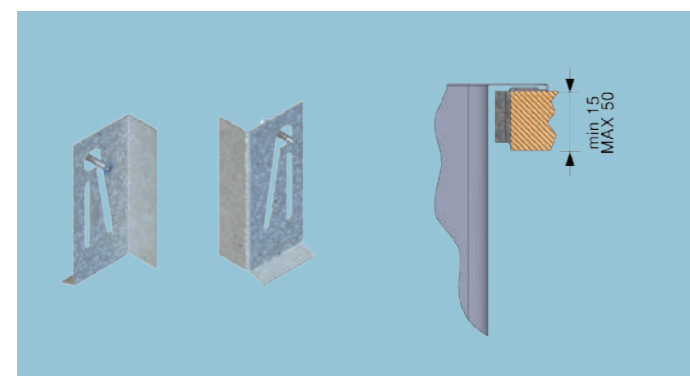

MM-00174

Sink Type: Topmount
Worktop Range: 15-50mm
Raw Material: Spring Steel (C45-C67)
 PA 6.6

Packing Options:
 Unpackaged
 Plastic Bag
 Cardboard box

Unpackaged Code	Master Carton Dims (cm)	PCS/ Box	PCS/ Pallet
MM-00176	38x38x12.5	200	9.600

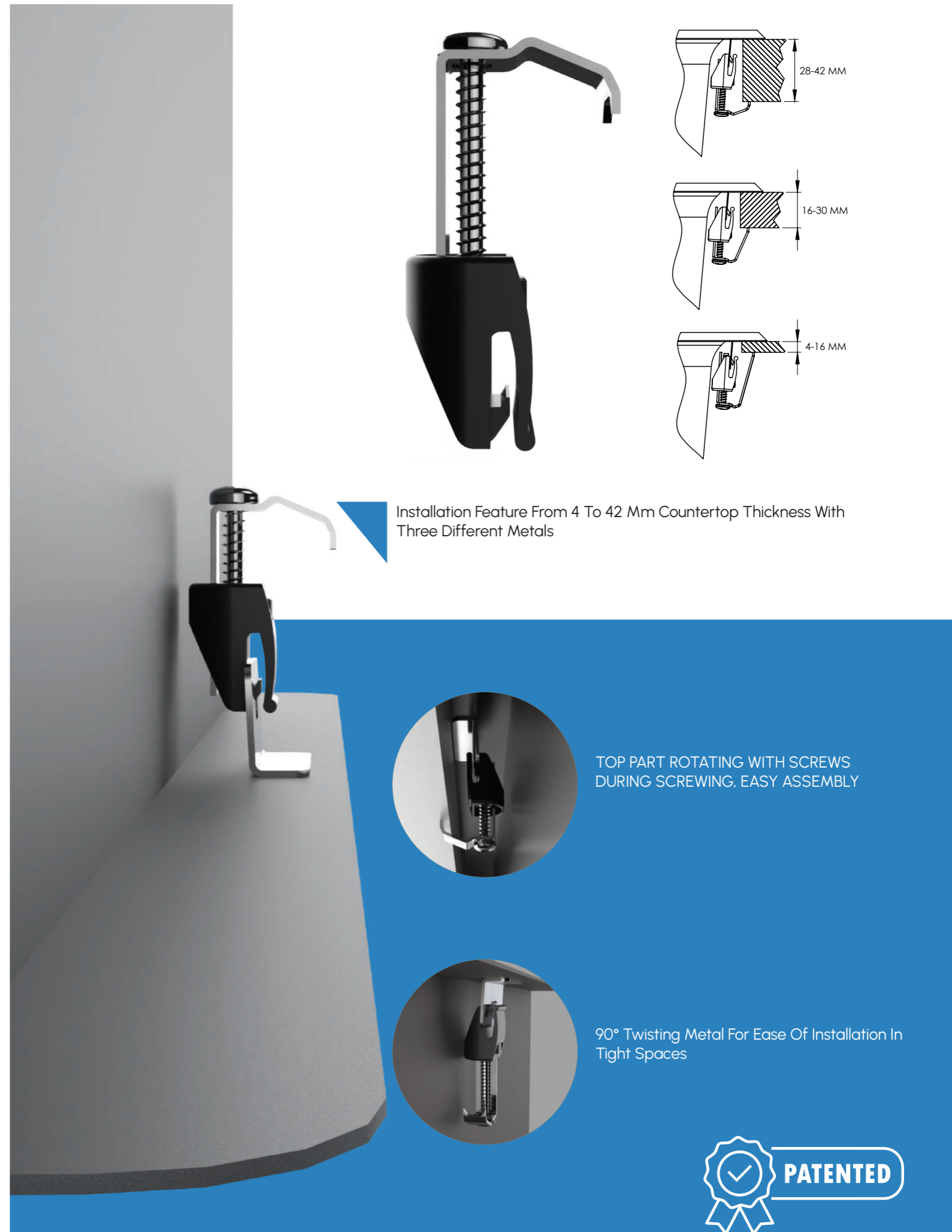

Installation Feature From 4 To 42 Mm Countertop Thickness With Three Different Metals

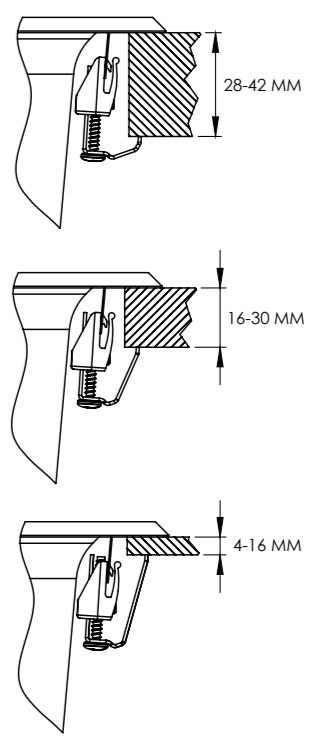

TOP PART ROTATING WITH SCREWS DURING SCREWING, EASY ASSEMBLY



90° Twisting Metal For Ease Of Installation In Tight Spaces

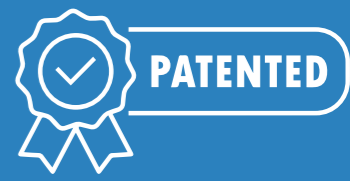

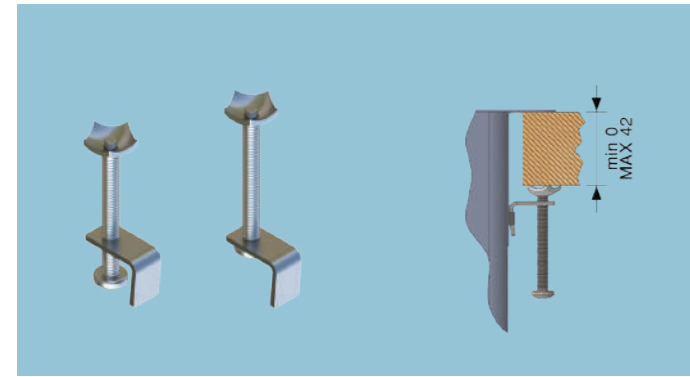

MM-00011

Sink Type: Topmount
Worktop Range: 0-42mm
Raw Material: DC01 Steel

Packing Options:
 Unpackaged
 Plastic Bag
 Cardboard box

Unpackaged Code	Master Carton Dims (cm)	PCS/ Box	PCS/ Pallet
MM-00012	55x24x25	1250	45.000

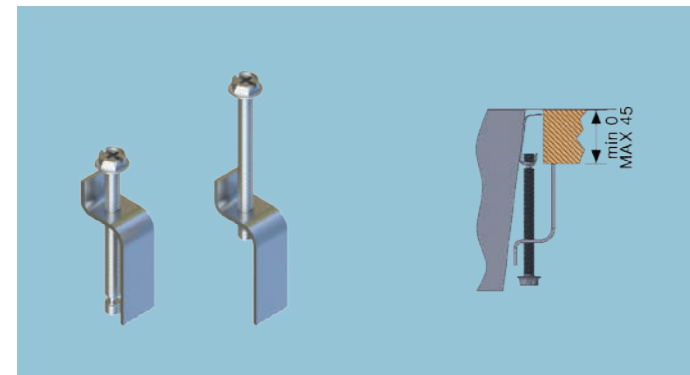

MM-00009

Sink Type: Topmount
Worktop Range: 0-45mm
Raw Material: DC01 Steel

Packing Options:
 Unpackaged
 Plastic Bag
 Cardboard box

Unpackaged Code	Master Carton Dims (cm)	PCS/ Box	PCS/ Pallet
MM-00010	55x24x25	1250	45.000

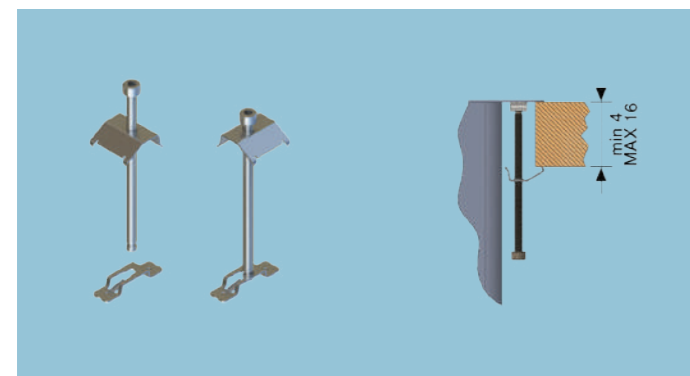

MM-00177

Sink Type: Topmount
Worktop Range: 4-16mm
Raw Material: Spring Steel (C45-C67)
 Stainless Steel 304

Packing Options:
 Unpackaged
 Plastic Bag
 Cardboard box

Unpackaged Code	Master Carton Dims (cm)	PCS/ Box	PCS/ Pallet
MM-00179	38x38x12.5	150	7.200

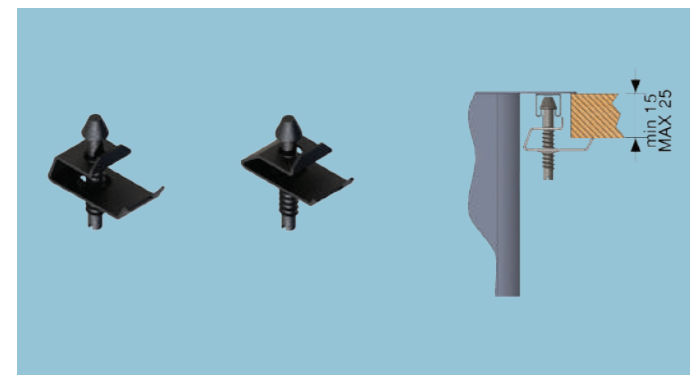

MM-00007

Sink Type: Topmount
Worktop Range: 15-25mm
Raw Material: Spring Steel (C45-C67)

Packing Options:
 Unpackaged
 Plastic Bag
 Cardboard box

Unpackaged Code	Master Carton Dims (cm)	PCS/ Box	PCS/ Pallet
MM-00008	55x24x25	2100	75.600

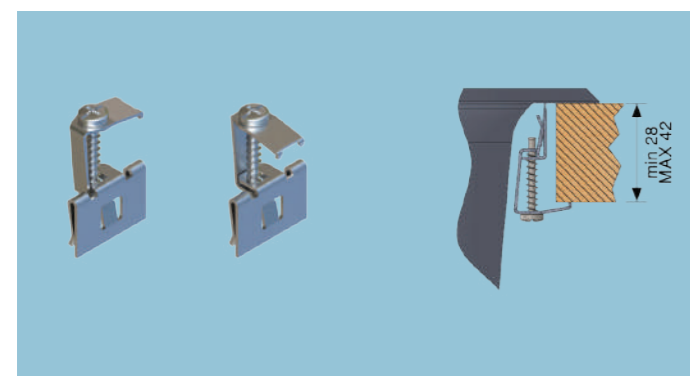

MM-00368

Sink Type: Topmount
Worktop Range: 28-42mm
Raw Material: Spring Steel (C45-C67)

Packing Options:
 Unpackaged
 Plastic Bag
 Cardboard box

Unpackaged Code	Master Carton Dims (cm)	PCS/ Box	PCS/ Pallet
82.800	55x24x25	2300	82.800

COMPOSITE GRANITE SINK CLIPS

Our Composite Granite Sink Clips, expertly crafted from high-grade stainless steel, ensure a secure and flush installation for your composite granite sinks. Designed for exceptional strength and resistance to corrosion, these clips keep your sink firmly in place, even under daily use.

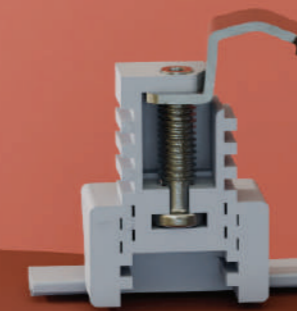

MM-00092

Sink Type: Topmount
 Worktop Range: 8-50mm
 Raw Material:
 Spring Steel / Galvanised Metal
 PA 6.6

Packing Options:
 Unpackaged
 Plastic Bag
 Cardboard box

Unpackaged Code	Master Carton Dims (cm)	PCS/ Box	PCS/ Pallet
MM-00093	55x24x25	2000	72.000

MM-00044

Sink Type: Topmount
 Worktop Range: 28-42mm
 Raw Material:
 Spring Steel (C45-C67)
 PA 6.6

Packing Options:
 Unpackaged
 Plastic Bag
 Cardboard box

Unpackaged Code	Master Carton Dims (cm)	PCS/ Box	PCS/ Pallet
MM-00045	55x24x25	1600	57.600

MM-00346

Sink Type: Topmount
 Worktop Range: 8-28mm
 Raw Material:
 Spring Steel (C45-C67)
 PA 6.6

Packing Options:
 Unpackaged
 Plastic Bag
 Cardboard box

Unpackaged Code	Master Carton Dims (cm)	PCS/ Box	PCS/ Pallet
MM-00347	55x24x25	1600	57.600

MM-00056

Sink Type: Topmount
 Worktop Range: 20-42mm
 Raw Material:
 Spring Steel (C45-C67)
 PA 6.6

Packing Options:
 Unpackaged
 Plastic Bag
 Cardboard box

Unpackaged Code	Master Carton Dims (cm)	PCS/ Box	PCS/ Pallet
MM-00057	55x24x25	2100	75.600

Mountable worktop thickness range: 20 to 40 mm

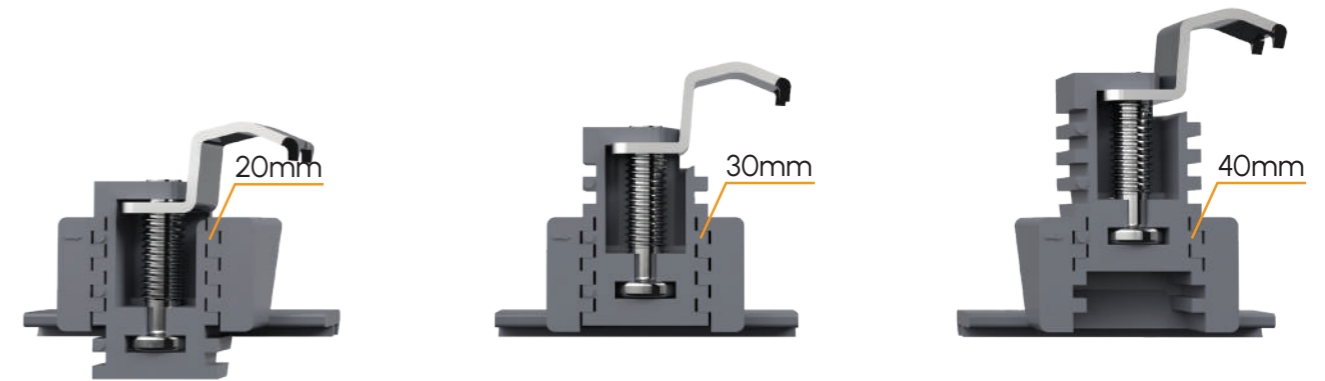

Single-move mounting from under the counter



Does not take up unnecessary space under the counter



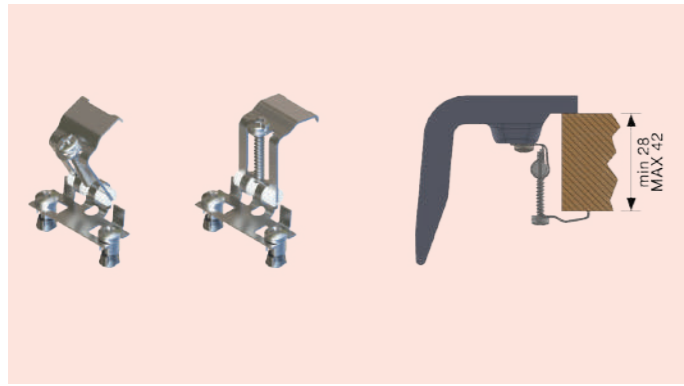

MM-00024

Sink Type: Topmount
Worktop Range: 28-42mm
Raw Material:
Spring Steel (C45-C67)
PA 6.6

Packing Options:
Unpackaged
Plastic Bag
Cardboard box

Unpackaged Code	Master Carton Dims (cm)	PCS/ Box	PCS/ Pallet
MM-00025	55x24x25	1600	57.600

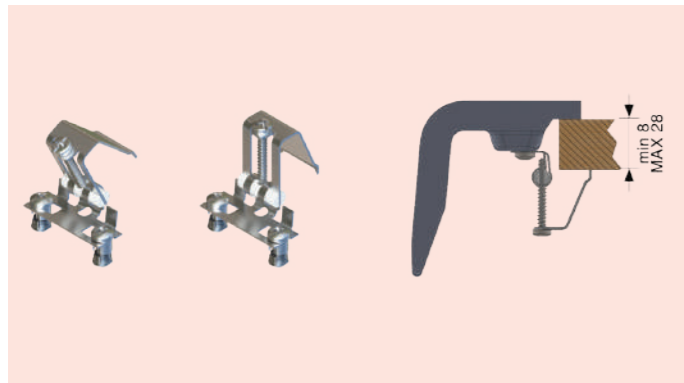

MM-00033

Sink Type: Topmount
Worktop Range: 8-28mm
Raw Material:
Spring Steel (C45-C67)
Metal Alloy PA 6.6

Packing Options:
Unpackaged
Plastic Bag
Cardboard box

Unpackaged Code	Master Carton Dims (cm)	PCS/ Box	PCS/ Pallet
MM-00034	55x24x25	1500	54.000

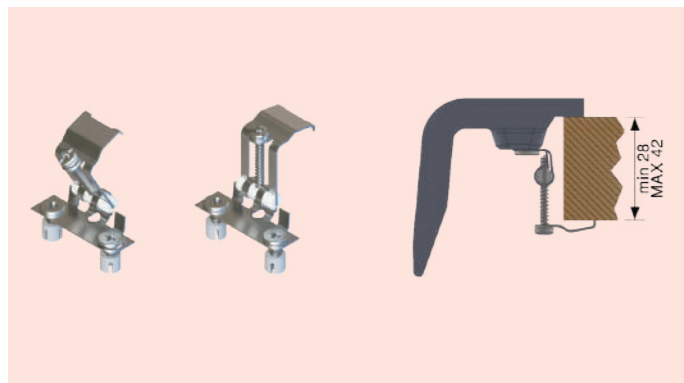

MM-00035

Sink Type: Topmount
Worktop Range: 28-42mm
Raw Material:
Spring Steel (C45-C67)
PA 6.6

Packing Options:
Unpackaged
Plastic Bag
Cardboard box

Unpackaged Code	Master Carton Dims (cm)	PCS/ Box	PCS/ Pallet
MM-00036	55x24x25	1600	57.600



MM-00042

Sink Type: Topmount
Worktop Range: 8-28mm
Raw Material:
Spring Steel (C45-C67)
PA 6.6

Packing Options:
Unpackaged
Plastic Bag
Cardboard box

Unpackaged Code	Master Carton Dims (cm)	PCS/ Box	PCS/ Pallet
MM-00043	55x24x25	1500	54.600

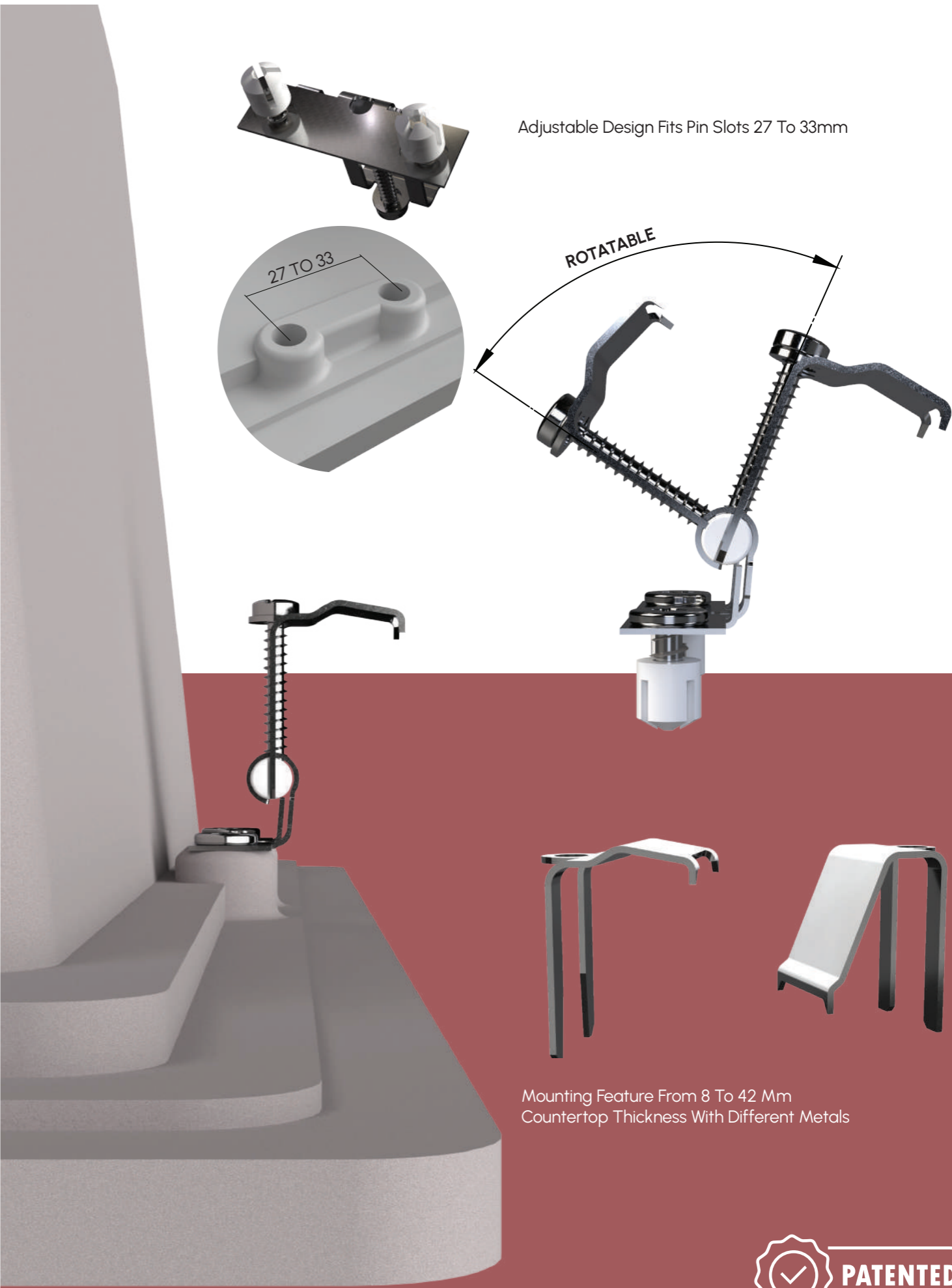

Adjustable Design Fits Pin Slots 27 To 33mm

ROTATABLE

27 TO 33

Mounting Feature From 8 To 42 Mm
Countertop Thickness With Different Metals

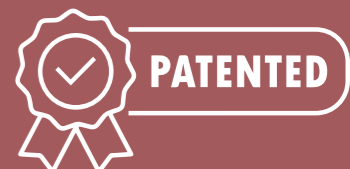

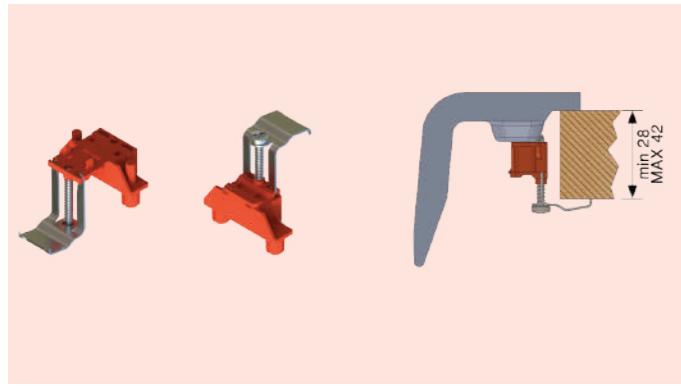

MM-00061

Sink Type: Topmount
Worktop Range: 28-42mm
Raw Material:
 Spring Steel (C45-C67)
 PA 6.6

Packing Options:
 Unpackaged
 Plastic Bag
 Cardboard box

Unpackaged Code	Master Carton Dims (cm)	PCS/ Box	PCS/ Pallet
MM-00062	55x24x25	1600	57.600

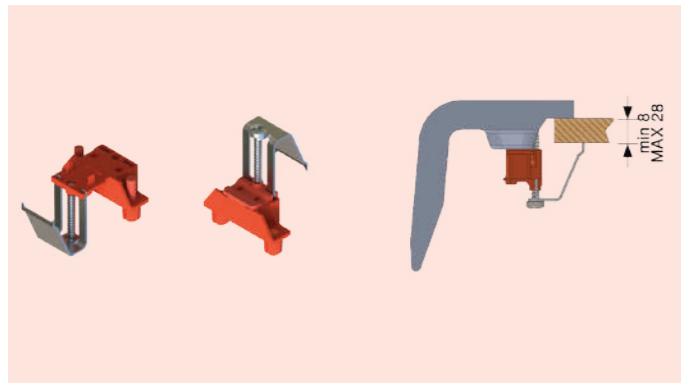

MM-00352

Sink Type: Topmount
Worktop Range: 8-28mm
Raw Material:
 Spring Steel (C45-C67)
 PA 6.6

Packing Options:
 Unpackaged
 Plastic Bag
 Cardboard box

Unpackaged Code	Master Carton Dims (cm)	PCS/ Box	PCS/ Pallet
MM-00353	55x24x25	1500	54.000

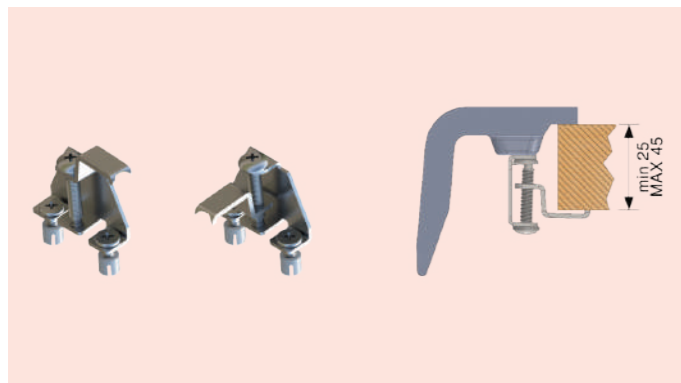

MM-00075

Sink Type: Topmount
Worktop Range: 25-45mm
Raw Material:
 DC01 Steel
 PA 6.6

Packing Options:
 Unpackaged
 Plastic Bag
 Cardboard box

Unpackaged Code	Master Carton Dims (cm)	PCS/ Box	PCS/ Pallet
MM-00077	55x24x25	92	3312

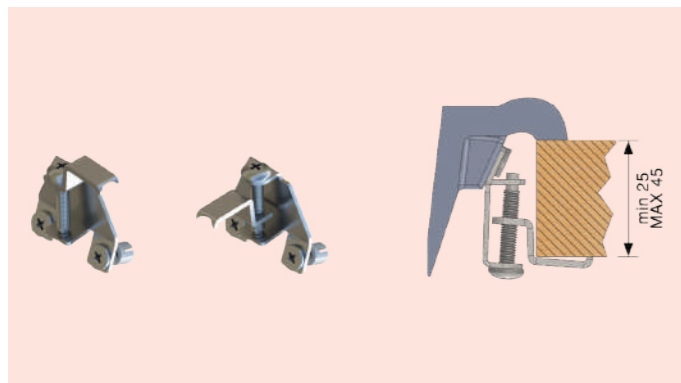

MM-00072

Sink Type: Topmount
Worktop Range: 25-45mm
Raw Material:
 Spring Steel (C45-C67)
 PA 6.6

Packing Options:
 Unpackaged
 Plastic Bag
 Cardboard box

Unpackaged Code	Master Carton Dims (cm)	PCS/ Box	PCS/ Pallet
MM-00074	55x24x25	92	3312

UNDERMOUNT SINK CLIPS

Our Undermount Sink Clips, crafted from high-quality stainless steel, provide exceptional stability and a flush installation for your sinks. Engineered for strength and corrosion resistance, these clips ensure your sink remains securely in place, even with daily use.



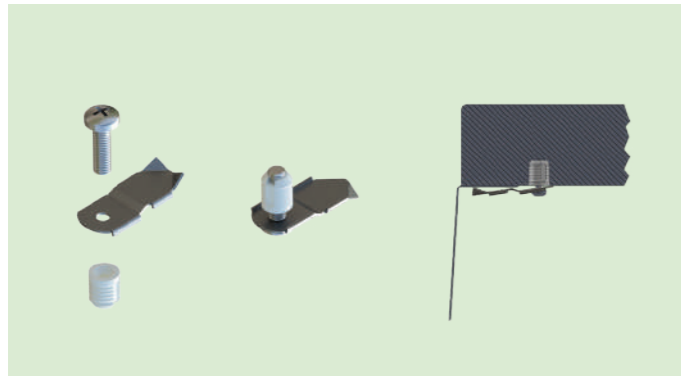

MM-00170

Sink Type: Undermount
Raw Material:
Stainless Steel 430
PA 6.6 Insert

Packing Options:
Unpackaged
Plastic Bag
Cardboard box

Plastic Bag (4pcs) Code	Master Carton Dims (cm)	PCS/ Box	PCS/ Pallet
MM-00172	38x38x12.5	325	15.600

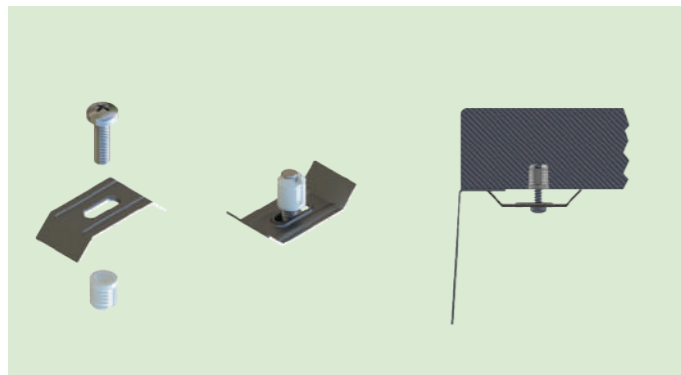

MM-00166

Sink Type: Undermount
Raw Material:
Stainless Steel 430
PA 6.6 Insert

Packing Options:
Unpackaged
Plastic Bag
Cardboard box

Plastic Bag (4pcs) Code	Master Carton Dims (cm)	PCS/ Box	PCS/ Pallet
MM-00357	38x38x12.5	310	14.880

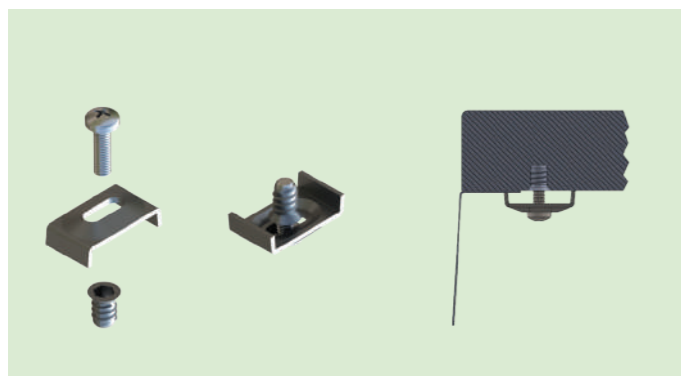

MM-00160

Sink Type: Undermount
Raw Material:
Stainless Steel 304
Metal Alloy

Packing Options:
Unpackaged
Plastic Bag
Cardboard box

Plastic Bag (4pcs) Code	Master Carton Dims (cm)	PCS/ Box	PCS/ Pallet
MM-00162	38x38x12.5	250	12.000

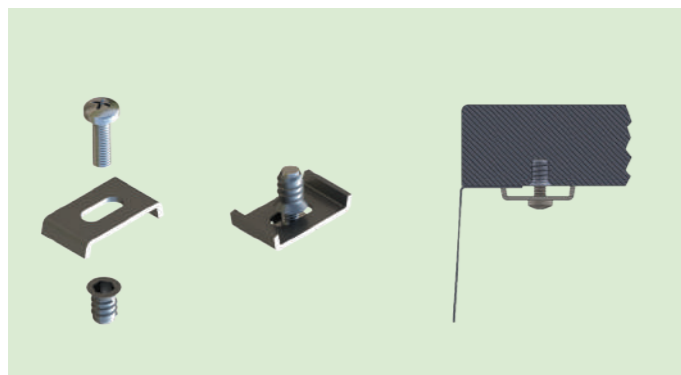

MM-00156

Sink Type: Undermount
Raw Material:
Stainless Steel 304
Metal Alloy

Packing Options:
Unpackaged
Plastic Bag
Cardboard box

Plastic Bag (4pcs) Code	Master Carton Dims (cm)	PCS/ Box	PCS/ Pallet
MM-00158	38x38x12.5	250	12.000

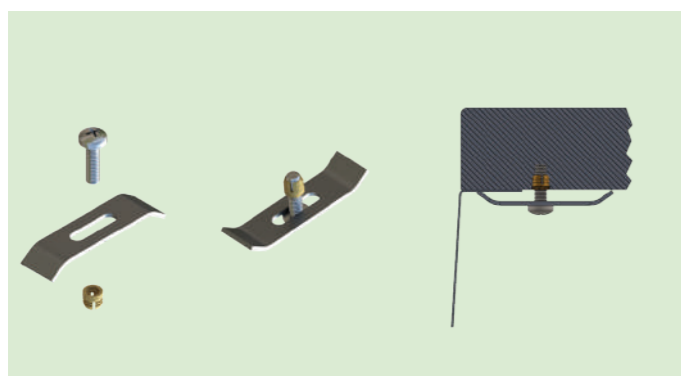

MM-00372

Sink Type: Undermount
Raw Material:
DC01 Steel
Brass Insert

Packing Options:
Unpackaged
Plastic Bag
Cardboard box

Plastic Bag (4pcs) Code	Master Carton Dims (cm)	PCS/ Box	PCS/ Pallet
MM-00375	38x38x12.5	200	9.600

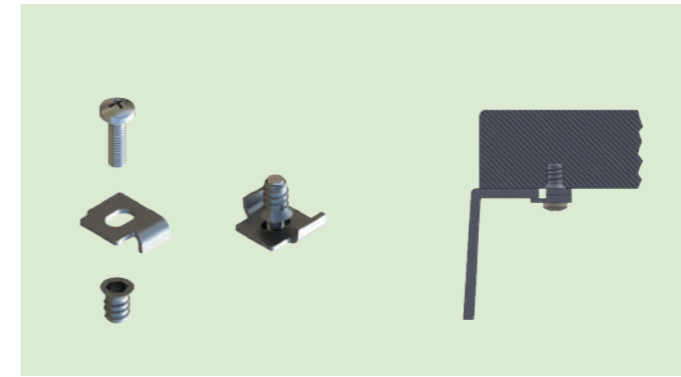

MM-00020

Sink Type: Undermount
Raw Material:
DC01 Steel
Metal Alloy

Packing Options:
Unpackaged
Plastic Bag
Cardboard box

Plastic Bag (4pcs) Code	Master Carton Dims (cm)	PCS/ Box	PCS/ Pallet
MM-00022	38x38x12.5	2000	15.600

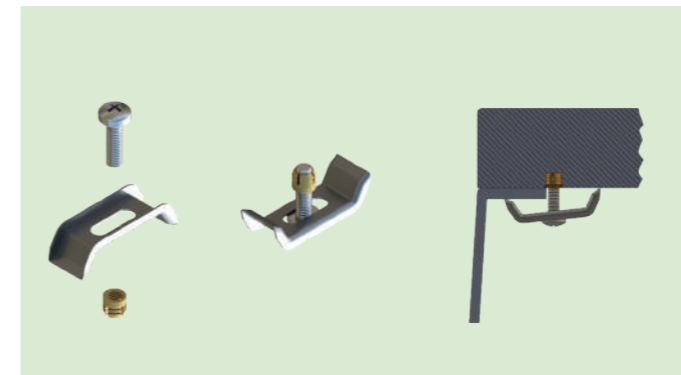

MM-00078

Sink Type: Undermount
Raw Material:
Stainless Steel 304
Brass Insert

Packing Options:
Unpackaged
Plastic Bag
Cardboard box

Plastic Bag (4pcs) Code	Master Carton Dims (cm)	PCS/ Box	PCS/ Pallet
MM-00080	38x38x12.5	225	10.800

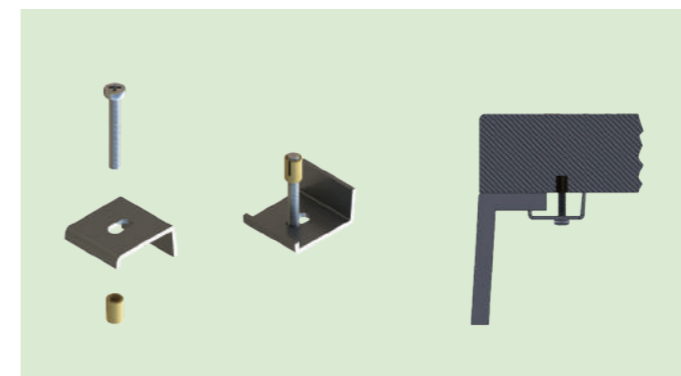

MM-00364

Sink Type: Undermount
Raw Material:
DC01 Steel
Brass Insert

Packing Options:
Unpackaged
Plastic Bag
Cardboard box

Plastic Bag (4pcs) Code	Master Carton Dims (cm)	PCS/ Box	PCS/ Pallet
MM-00376	38x38x12.5	300	14.400

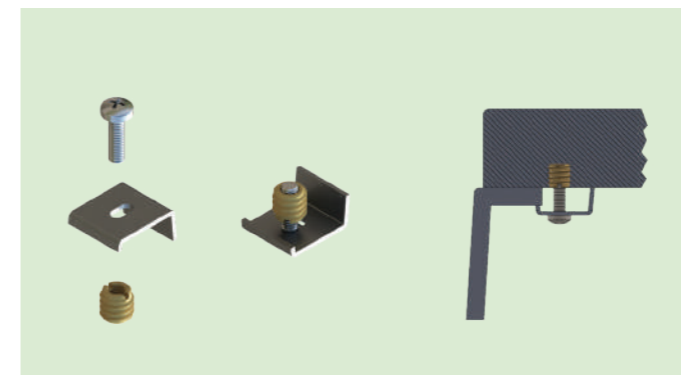

MM-00366

Sink Type: Undermount
Raw Material:
DC01 Steel
Brass Insert

Packing Options:
Unpackaged
Plastic Bag
Cardboard box

Plastic Bag (4pcs) Code	Master Carton Dims (cm)	PCS/ Box	PCS/ Pallet
MM-00377	38x38x12.5	250	14.400

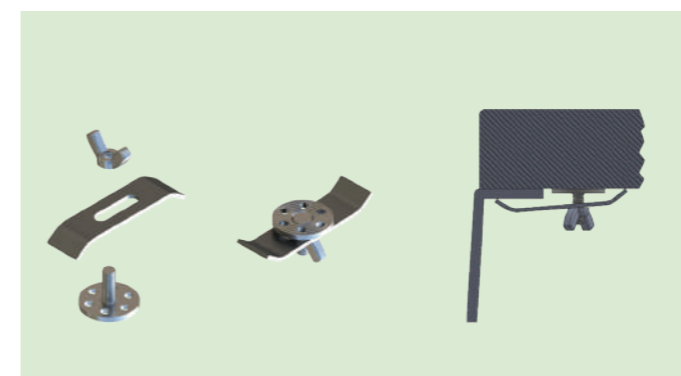

MM-00378

Sink Type: Undermount
Raw Material:
DC01 Steel
Butterfly Nut

Packing Options:
Unpackaged
Plastic Bag
Cardboard box

Plastic Bag (4pcs) Code	Master Carton Dims (cm)	PCS/ Box	PCS/ Pallet
MM-00380	38x38x12.5	250	12.000

SPARE PARTS

High-grade stainless steel clips for secure and flush installation. Corrosion-resistant, universally compatible, and easy to install. Perfect for replacing or upgrading existing parts.

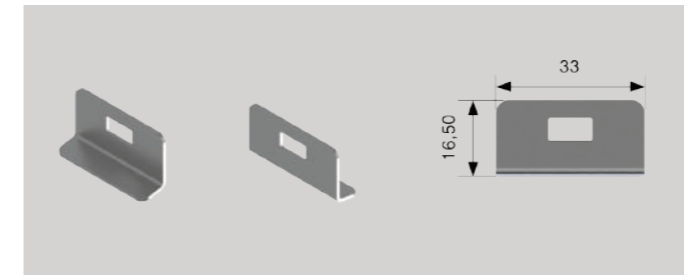
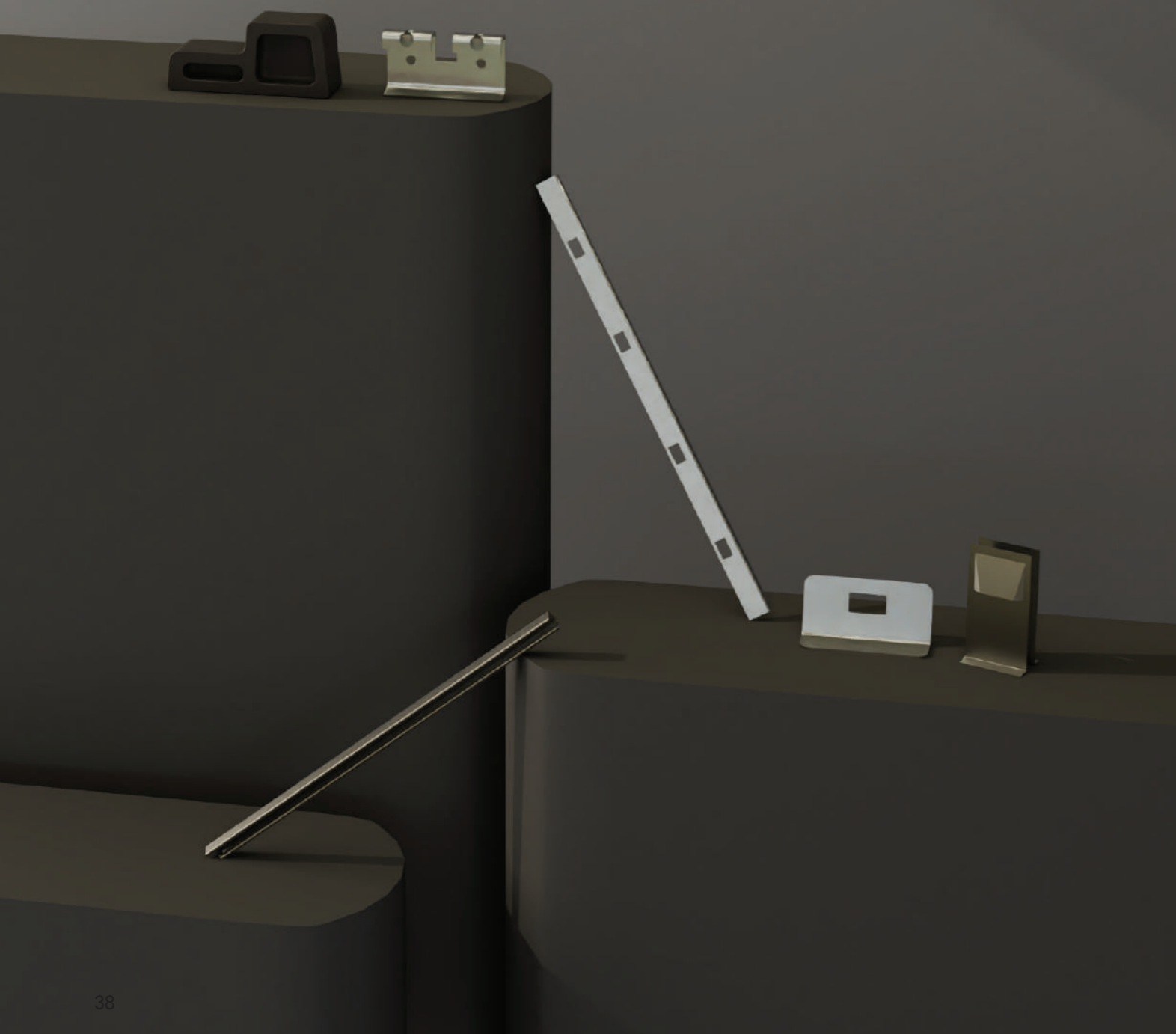

YM-00120

Clip Handling Metal Piece

Raw Material: Stainless Steel

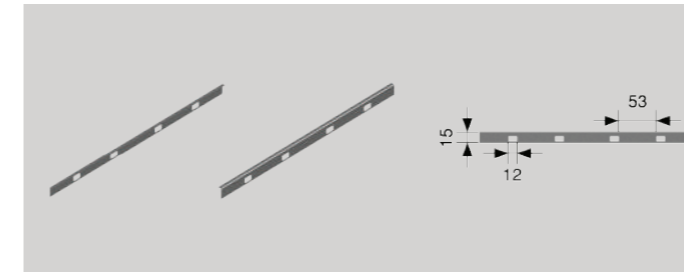

YM-00161

Clip Handling Metal Piece
Changeable Length

Raw Material: Stainless Steel

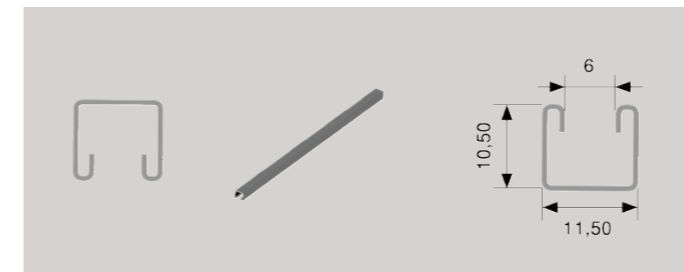

YM-00152

Clip Handling Metal Piece
Changeable Length

Raw Material: Stainless Steel Galvanized



YM-00015

Hanging Clip Accessories

Raw Material: Stainless Steel

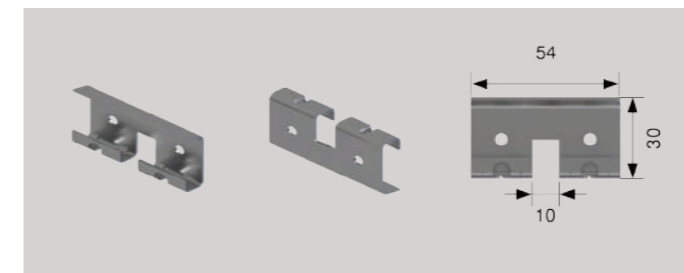

YM-00350

Hanging Clip Accessories

Raw Material: Stainless Steel

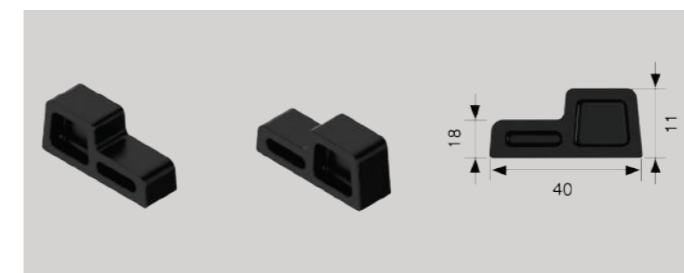

YM-00146

Plastic Chock
Two Stages For Low Range

Raw Material: PP

FOAM ISOLLATION PRODUCTS

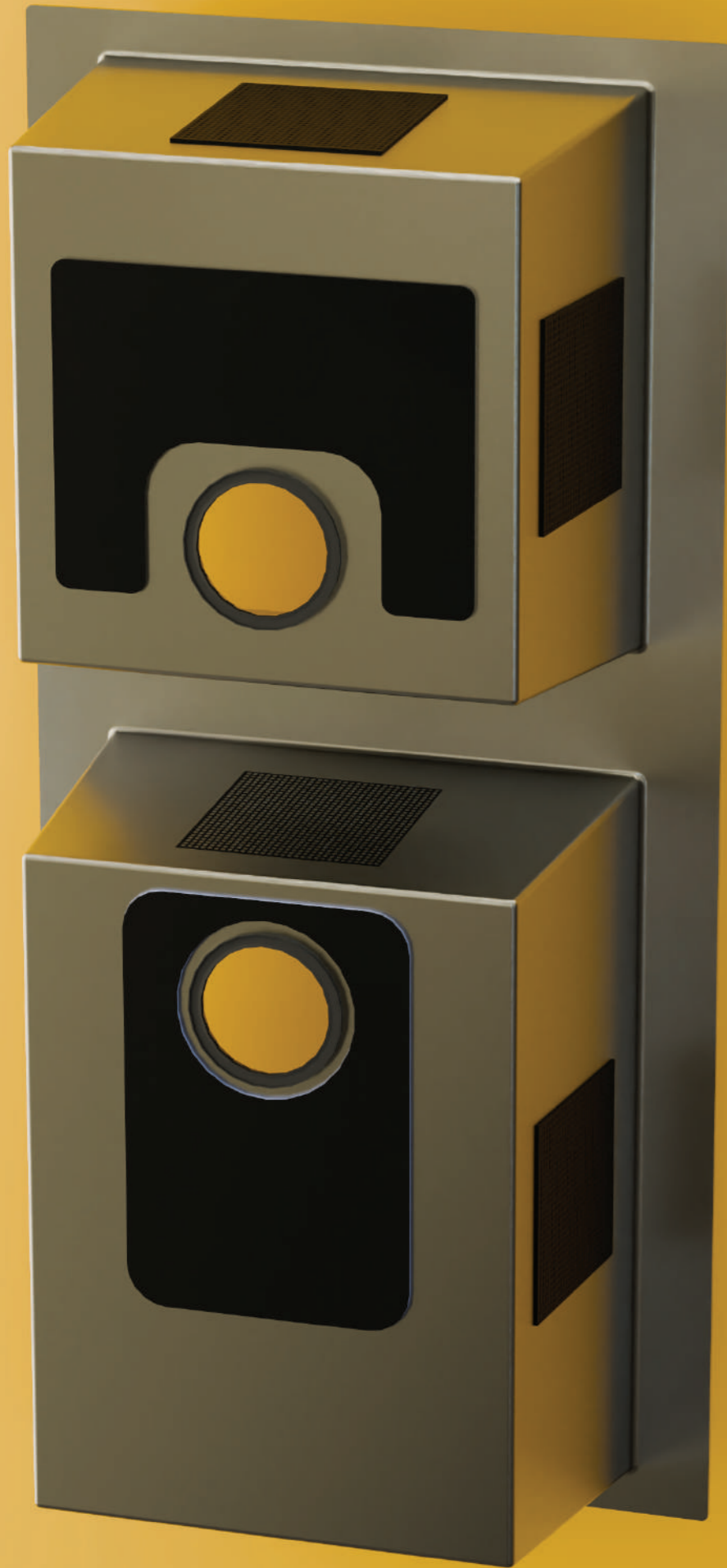

SOUND DEANER PADS

Shapes & Sizes Adaptable

Sound Deaner Pads & Sealing Tapes With Any Dimensions Or Shape Are Available

BITUM COMPOSITION



EVA FOAM

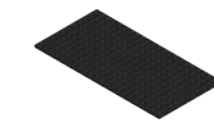
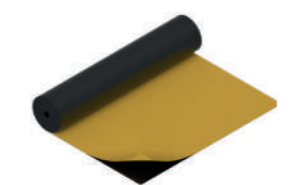

10*15 cm



11*12 cm



23*30 cm



35*35cm



15*15 cm

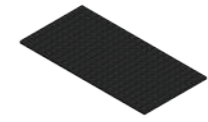

10*15 cm



11*12 cm



23*30 cm



35*35cm

SEALING TAPES

Shapes & Sizes Adaptable

Different Density & Thickness Of Sponges Bitumen Rubber Metarials Can Be Produced



XPE FOAM



EVA FOAM

Pressed



Roll



1.60

1.86

2.65

3.20

3.50

Pressed



Roll



1.60

1.86

2.65

3.20

3.50

**THE CORE
OF FASTENING,
THE ESSENCE
OF DURABILITY.**

More Information :

Sazlıbosna Mah, Haraççı-Hadımköy Yolu
No:202, 34555 Arnavutköy İstanbul / Turkey
www.direncgroup.com